

# CTM Magnetic Drive Centrifugal Pumps

Original Instruction  
2025 | 1



Read this instruction manual carefully,  
before you install and operate the pump



## Pump models:

CTM20-7

CTM25-8

CTM25-10

CTM32-12.5

CTM40-12.5

CTM50-12.5



# CONTENTS

---

<b>EC DECLARATION OF CONFORMITY 01/EC/CTM/2016</b> .....	3
<b>0. GENERAL</b> .....	4
<b>0.1. Introduction</b> .....	4
<b>0.2. Warning symbols</b> .....	4
<b>0.3. Qualification and training of personnel</b> .....	4
<b>1. INSTALLATION</b> .....	5
<b>1.1. Operation principle</b> .....	5
<b>1.2. Receiving inspection</b> .....	5
<b>1.3. Lifting and transportation</b> .....	6
<b>1.4. Storage</b> .....	6
<b>1.5. Foundation</b> .....	6
<b>1.6. Environment</b> .....	7
<b>1.7. Suction and discharge piping</b> .....	7
<b>1.7.1. Connection of discharge pipe</b> .....	7
<b>1.7.2. Connection of suction pipe</b> .....	7
<b>1.8. Health and safety</b> .....	8
<b>1.8.1. Protection</b> .....	8
<b>1.8.2. Electrical safety</b> .....	8
<b>1.8.3. Chemical hazard</b> .....	8
<b>1.8.4. Dry running</b> .....	8
<b>1.8.5. Noise level</b> .....	8
<b>1.8.6. Temperature hazards</b> .....	8
<b>1.8.7. Rotating parts</b> .....	9
<b>1.8.8. Powerful magnetic field</b> .....	9
<b>1.9. Solids</b> .....	9
<b>1.10. Example of installation</b> .....	10
<b>1.11. Instruments</b> .....	11
<b>1.11.1. Electric power</b> .....	11
<b>1.11.2. Optional instruments</b> .....	11
<b>1.11.3. Thermometer</b> .....	11
<b>1.12. Motor connection</b> .....	11
<b>1.13. Motor standard</b> .....	12
<b>2. OPERATION</b> .....	13
<b>2.1. Start-up</b> .....	13
<b>2.1.1. Starting the pump</b> .....	13

# CONTENTS

---

2.1.2.	Restarting after power shut-off.....	13
2.2.	Stopping the pump.....	14
2.3.	Residual risks.....	14
2.4.	Disposal after expiration of the expected lifetime .....	14
2.5.	Waste of electrical and electronic equipment (WEEE) directive .....	14
2.6.	Actions in emergency .....	14
3.	MAINTENANCE .....	15
3.1.	Inspections.....	15
3.2.	Location of faults .....	16
3.3.	Disassembly of the pump.....	17
3.3.1.	Disassembly procedure.....	17
3.4.	Assembly of the pump.....	20
3.4.1.	Test run .....	20
4.	SPARE PARTS.....	21
4.1.	Spare parts drawing.....	21
4.2.	Spare parts list.....	21
4.3.	Recommended spare parts.....	22
4.4.	How to order parts.....	22
5.	DATA .....	23
5.1.	Pump code .....	23
5.2.	Dimensions .....	24
5.3.	Materials, data and limits.....	25
5.4.	Mounting torques and dimensions of screws/nuts .....	25
5.5.	Performance curves .....	Błąd! Nie zdefiniowano zakładki.
5.6.	Permitted loads on inlet and outlet .....	27
6.	WARRANTY .....	28
6.1.	Returning parts .....	28
6.2.	Warranty .....	28
6.3.	Warranty form.....	30

## EC DECLARATION OF CONFORMITY 01/EC/CTM/2016

Series:

**CTM...**

Serial numbers:

**2016 - ... (from 1604 - ...)**

Manufactured by:

**Tapflo AB**

**Filaregatan 4**

**442 34 Kungälv, Sweden**

This declaration of conformity is issued under the sole responsibility of the manufacturer.

Object of declaration: **SINGLE STAGE MAGNETIC COUPLED CENTRIFUGAL PUMPS**

The object of the declaration described above is in conformity with the relevant Union harmonization legislation:

- Directive 2006/42/EC of European Parliament and of the Council of 17 May 2006 on machinery, amending Directive 95/16/EC;
- Directive 2014/35/UE of the European Parliament and of the Council of 14 February 2014 on harmonization of the laws of Member States relating to electrical equipment designed for use within certain voltage limits;

Mr Michał Śmigiel is authorized to compile the technical file.

Tapflo Sp. z o.o.  
ul. Czatkowska 4b  
83-110 Tczew

Signed for and on behalf of Tapflo AB:



Håkan Ekstrand  
**Managing director**

Tapflo AB, 16.04.2016

# 0. GENERAL

---

## 0. GENERAL

### 0.1. Introduction

CTM is a compact and reliable magnetically driven centrifugal pump made in PP and PVDF. With proper attention to maintenance, CTM pumps will give efficient and trouble free operation. This instruction manual will familiarise operators with detailed information about installing, operating and maintaining the pump.

### 0.2. Warning symbols

The following warning symbols are present in this instruction manual. This is what they say:



This symbol stands next to all safety instructions in this instruction manual where danger to life and limb may occur. Observe these instructions and proceed with utmost caution in these situations. Inform also other users of all safety instructions. In addition to the instructions in this instruction manual, the general safety and accident prevention regulations must be observed.



This signal stands at points in this instruction manual of particular importance for compliance with regulations and directives, for correct work flow and for the prevention of damage to and destruction of the complete pump or its subassemblies.



This symbol indicates possible danger caused by strong magnetic field in the vicinity of the pump.



This symbol signals possible danger caused by the presence of electric fields or live wires.

### 0.3. Qualification and training of personnel



The personnel in charge of installation, operation and maintenance of the pumps we produce must be qualified to carry out the operations described in this manual. Tapflo shall not be held responsible for the training level of personnel and for the fact that they are not fully aware of the contents of this manual. In case any instructions in this manual are unclear or any information is lacking, please contact Tapflo before handling the pump.

# 1. INSTALLATION

---

## 1. INSTALLATION

### 1.1. Operation principle

In the CTM pump the torque from the motor shaft is transmitted to the impeller by means of a magnetic coupling. The drive magnet (1) is fixed on the motor shaft. The magnets installed in the drive magnet and in the impeller/magnet assembly (2) have different polarity. When the pump is at rest, the magnets of both parts are aligned. When the motor is started and the drive magnet starts to rotate, the magnets create an attraction and repulsion force thus forcing the impeller to rotate. If the impeller gets blocked or the pumped liquid will be too dense and too much torque will be generated on the motor shaft, the magnet will de-couple and no damaged will be done to the motor. When the pump will come to a stop, the magnets will re-couple. Between both magnet assemblies there is located an isolation shell (3) that separates the liquid side from the motor side.

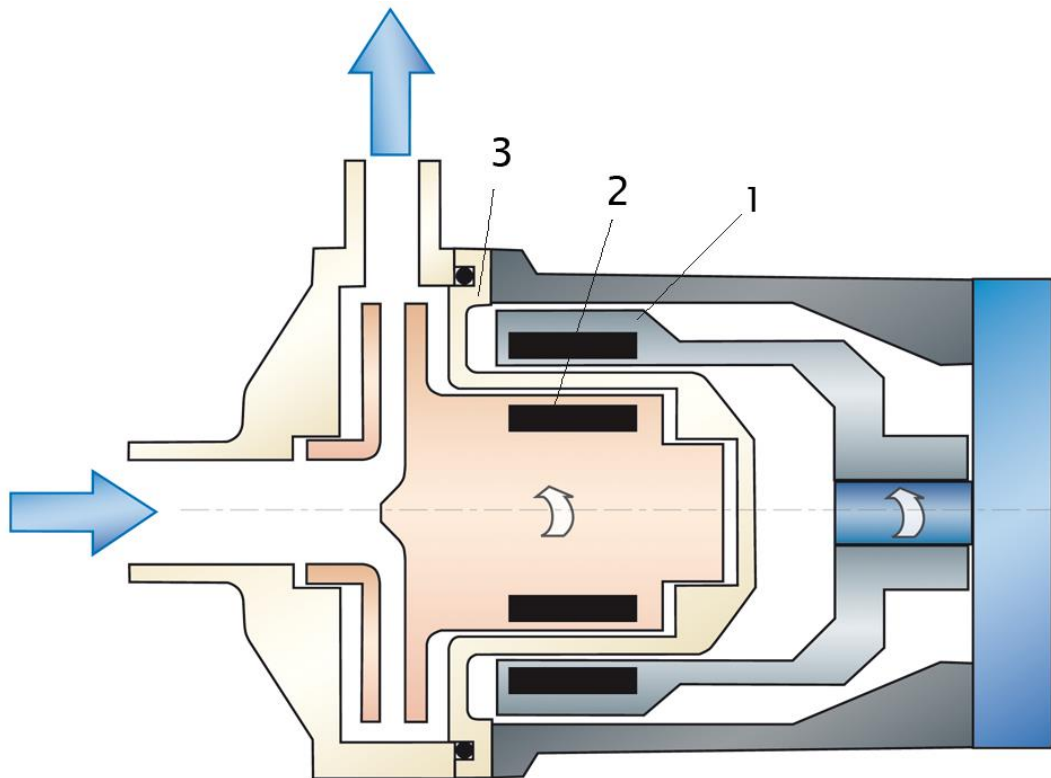

### 1.2. Receiving inspection

Although precaution is taken by us when packing and shipping, we urge you to carefully check the shipment on receipt. Make sure that all parts and accessories listed on the packing list are accounted for. Immediately report any damage or shortage to the transport company and to us.

# 1. INSTALLATION

## 1.3. Lifting and transportation



Before handling the pump check the weight of the pump (see 5.2. *Dimensions*). Refer to Your local standards on how to handle the pump. If the weight is excessive to transport by hand it must be lifted using slings and a suitable lifting device e.g. a crane or forklift.

Always use at least two slings and make sure they are secured in such a way to prevent the pump from slipping and that the pump unit is hanging straight.

Never lift the pump with only one sling. Incorrect lifting can cause serious injury and/or damage to the pump.

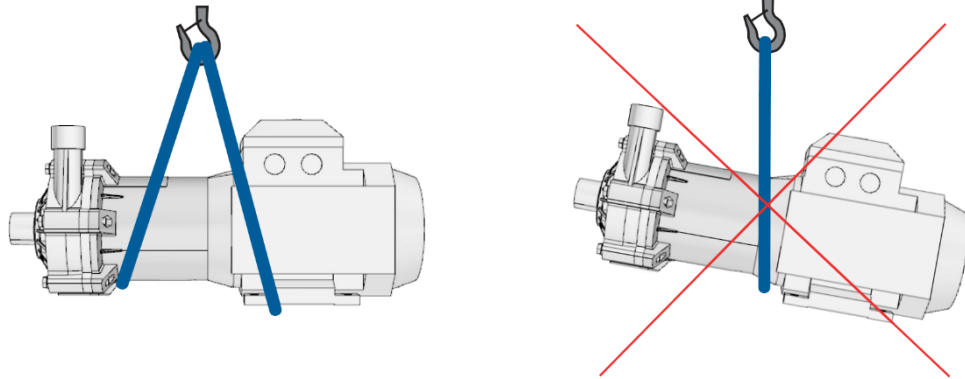

Never lift the pump under pressure.

Be careful that nobody passes under the pump when lifted.

Never try to lift the pump by the manifolds or hoses attached to the pump.

## 1.4. Storage



If the equipment is to be stored prior to installation, place it in a clean location. Clean the pump thoroughly before installation.

## 1.5. Foundation



The pump-motor unit must stand on and be fixed to a sufficiently rigid structure that can support the entire perimeter on which the unit stands. The foundation on a firm bottom is the most satisfactory. Once the pump is in position, adjust level with metal shims between the feet and the surface on which it stands. Check that the feet of the pump-motor unit stand well on each of them. The surface on which the foundation stands must be flat and horizontal. If the unit is fitted on a steel structure, make sure that it is supported so that the feet do not warp. In any case, it is advisable to fit some anti-vibration rubber pieces between the pump and the brickwork.

For close-coupled type, pump motor alignment is not required.

# 1. INSTALLATION

---

## 1.6. Environment



- There should be enough space in the vicinity of the pump in order to operate, maintain and repair it.
- The area in which the pump is operated, must be sufficiently ventilated. Excessive temperature, humidity or dirt may affect the pump operation.
- Behind the cooling fan of the motor there must be sufficient room for the hot air to escape the motor.

## 1.7. Suction and discharge piping



A pump is generally part of a piping system that can include a number of components such as valves, fittings, filters, expansion joints, instruments, etc. The way the piping is arranged and the positioning of the components has a great influence on the operation and the lifetime of the pump. The pump cannot be used as a support for the components connected to it.

The flow of liquid from the pump must be as even as possible. It is advisable to avoid any tight bends or drastic reductions of diameters that may cause flow resistance in the installation. In case of diameter reduction, it is advisable to use appropriate conical reductions (possibly eccentric on suction side and concentric on discharge side) at changes of diameter and at a minimum distance from pump connections of five diameters.

### 1.7.1. Connection of discharge pipe



A shut-off / regulation valve is normally fitted on the discharge side. It cuts off the pump from the line and adjusts the output. Never adjust flow rate using the valve on the suction pipe.

### 1.7.2. Connection of suction pipe



The suction piping is very important for the correct operation of the pump assembly. It must be as short and as direct as possible. If a longer suction line is unavoidable, the diameter should be large enough, i.e. at least as the inlet connection on the pump, to ensure less flow resistance. In any case, suction must be carried out properly avoiding any air locks.



The CTM pumps are single-stage centrifugal type, thus non self-priming. It will therefore always be necessary to install a bottom valve in all cases when the static height of the liquid is lower than the suction height of the pump. The suction piping must be without air inlets that are more probable with long suction lines or if suction occurs with negative head. Critical points in these terms are also the seals between flanges and the seals of the valve stems. Even a bit of air let into the suction line can cause serious operating problems that can make the pump stop.



# 1. INSTALLATION

---

## 1.8. Health and safety

The pump must be installed according to local and national safety rules.



**The pumps are constructed for particular applications. Do not use the pump on applications different from that for which it was sold without consulting us to ascertain its suitability.**

### 1.8.1. Protection



In the interest of health and safety it is essential to wear protective clothing and safety goggles when operating, and/or working in the vicinity of Tapflo pumps.

### 1.8.2. Electrical safety



Do not carry out any maintenance or/and operation on the pump while it is running or before it has been disconnected from the power supply. Avoid any danger caused by electric power (for details see current regulations in force). Check that electrical specifications on the motor nameplate are equivalent to the power supply to which it will be connected.

### 1.8.3. Chemical hazard



Whenever the pump is to be used for pumping a different liquid, it is essential to clean the pump beforehand in order to avoid any possible reaction between the two products. Before pump disassembly clean it thoroughly.

### 1.8.4. Dry running



Do not start nor carry out running tests before filling the pump with liquid. Always avoid dry operation of the pump. Start the pump when it is completely filled and with the valve on the discharge side almost completely closed.

### 1.8.5. Noise level



CTM pumps, including the motor, in normal operating conditions produce a sound level below 80 dB(A). The major sources of noise are: liquid turbulence in the installation, cavitation or any other abnormal operation that is independent from the pump construction nor the pump manufacturer. The user must provide suitable protective means if the sources of noise could produce a harmful noise level for operators and for the environment (in compliance with current local regulations).

### 1.8.6. Temperature hazards



Raised temperature can cause damage on the pump and/or piping and may also be hazardous for personnel in the vicinity of the pump/piping. The hot or cold parts of the machine must be protected to avoid accidental contacts

# 1. INSTALLATION

---

## 1.8.7. Rotating parts



Do not tamper with the protection of the rotating parts, do not touch or approach rotating parts in movement.

## 1.8.8. Powerful magnetic field



Magnetically driven pumps use high intensity magnets. All pacemaker carriers must not approach magnetic components; intense magnetic field can disturb heart pace.

## 1.9. Solids



It is not recommended to use liquid with suspended solids, especially if sensitive to magnetism. In case dirty liquids are to be pumped and this was not mentioned at the time of ordering, it is necessary to contact Tapflo technical service before activating the pump. Acceptable solid size for all CTM pumps is 0,1 mm (100 microns). Maximum solids concentration by weight is 2%.

# 1. INSTALLATION

## 1.10. Example of installation

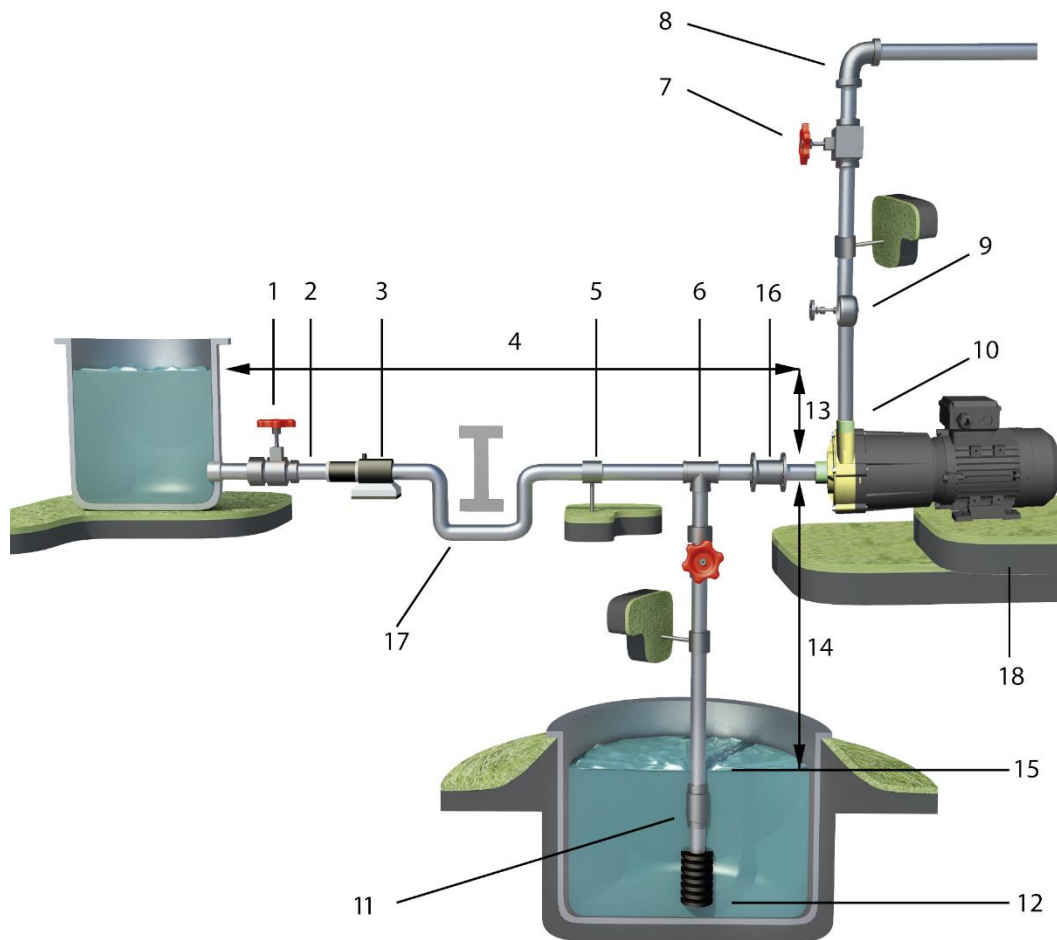

- 1) YES: Gate valve (may also be near pump in case of long piping)
- 2) With positive head: tilt of piping towards pump
- 3) YES: line strainer if particles are present
- 4) NO: air pockets – the circuit must be short and straight
- 5) YES: pipe fastening
- 6) Suction line as short and direct as possible
- 7) YES: adjusting gate valve on outlet
- 8) Bends placed after valves and instruments
- 9) YES: attachment for gauge or safety pressure switch
- 10) NO: elbow joints (and other parts) on the pump (discharge and suction lines)
- 11) YES: check valve (with negative suction lift)
- 12) YES: strainer if particles are present
- 13) Suction head varies according to flow in order to prevent windage
- 14) Suction head
- 15) Immersion depth
- 16) YES: expansion joint (necessary with long pipes or hot liquids) and/or anti-vibration facility during discharge and suction; anchored near to pump
- 17) YES: overcoming obstacles at lower depths
- 18) Fix the pump by the fixing holes provided: the supports must be level

# 1. INSTALLATION

## 1.11. Instruments



In order to ensure a proper control of the performance and the conditions of the installed pump, we recommend using the following instruments:

- a pressure-vacuum gauge on the suction piping;
- a pressure gauge on the discharge piping.

The instruments must be installed on straight pieces of piping at a distance not bigger than five diameters of the pipeline from the pump connections. The pressure gauge on discharge must always be fitted between the pump and the shut-off / regulation valve. The output can be read on the pressure gauge, transformed into meters and then compared with the typical curves.

### 1.11.1. Electric power

The electric power absorbed by the motor can be measured by means of a wattmeter.

### 1.11.2. Optional instruments

The optional instruments can indicate if pump is working in an abnormal way. The abnormal conditions can be caused by: accidentally closed valves, lack of pumped liquid, overloads, etc.

### 1.11.3. Thermometer

If the temperature of the pumped liquid is a critical parameter, provide the installation with a thermometer (preferably on the suction side).

## 1.12. Motor connection



An expert electrician must always carry out the electrical connection. Compare the power supply with the data plate specifications and then choose a suitable connection. The type of connection is stated on the motor data plate and can be Y (star) or D (Delta), according to the power supply of the motor (see table below).

STAR	DELTA

Follow the connection standard used in the plant. In no case connect the electrical motor directly to supply network but use a suitable electric switchboard equipped with a knife switch and suitable safety devices (e.g. motor breaker switches) in the power circuit. Safety



# 1. INSTALLATION

devices against overloads must also protect the motors. Make sure that the motor has suitable grounding and that it has been connected properly.

## 1.13. Motor standard

As a standard Tapflo CTM pumps are equipped with motors of the following parameters:

- International Mounting Arrangement – **B34**
- Number of poles / Rotation speed [rpm] – **2**
- **Non ATEX**
- Protection grade – **IP55**
- Voltage – **3 phase**

Motor power	RPM	Voltage	Frequency
<b>0.12 kW</b>	2800	$\Delta$ 230 / Y400	50 Hz
	3400	$\Delta$ 265 / Y460	60 Hz
<b>0.25 kW</b>	2800	$\Delta$ 230 / Y400	50 Hz
	3400	$\Delta$ 265 / Y460	60 Hz
<b>0.55 kW</b>	2800	$\Delta$ 230 / Y400	50 Hz
	3400	$\Delta$ 265 / Y460	60 Hz
<b>0.75 kW</b>	2900	$\Delta$ 230 / Y400	50 Hz
	3500	Y460	60 Hz
<b>1.1 kW</b>	2900	$\Delta$ 230 / Y400	50 Hz
	3500	Y460	60 Hz
<b>1.5 kW</b>	2900	$\Delta$ 230 / Y400	50 Hz
	3500	$\Delta$ 265 / Y460	60 Hz
<b>2.2 kW</b>	2900	$\Delta$ 230 / Y400	50 Hz
	3500	Y460	60 Hz
<b>3.0 kW</b>	2900	$\Delta$ 230 / Y400	50 Hz
	3500	$\Delta$ 265 / Y460	60 Hz
<b>4.0 kW</b>	2900	$\Delta$ 400 / Y690	50 Hz
	3500	$\Delta$ 460	60 Hz

## 2. OPERATION

---

### 2. OPERATION

#### 2.1. Start-up

- Check manually that the motor is free to turn by moving the motor cooling fan.
- Make sure that the piping is not clogged and is free from residues or foreign objects. Make sure that the liquid flows regularly into the pump.



- The pump and piping connected to it, at least the suction pipe, must be full of liquid. Any air or gas must be carefully released. In case of suction with negative head, fill the suction piping and check how the bottom valve works. It must guarantee that the liquid must not flow back, emptying therefore the suction pipe and eventually disconnection of the pump.

- The suction shut-off valve (if any) must be completely open.



- The shut-off / regulation valve on the discharge side must be completely closed.

- The motor must turn in the same direction as the arrow shown on the pump. The direction of rotation is always clockwise looking at the pump from the motor side; check by starting briefly, then looking at the direction of rotation of the motor fan through the fan lid. If it is wrong, the motor must be stopped immediately. Change the connection to the terminals of the electric motor (chapter 1.11 "Motor connection") and repeat the procedure described above.



- Any auxiliary connections must all be connected.

##### 2.1.1. Starting the pump



Start the electric motor and open the discharge adjustment/shutoff valve gradually until the desired output has been reached. The pump must not turn more than two or three minutes with discharge closed. A longer operation in these conditions can damage the pump seriously.

If the pressure shown on the pressure gauge on the discharge piping does not increase, turn off the pump immediately and release pressure carefully. Repeat the connection procedure.



If there are changes of flow rate, head, density, temperature or viscosity of the liquid, stop the pump and get in touch with our technical service.

##### 2.1.2. Restarting after power shut-off

In case of accidental stopping, make sure that the non-return valve has prevented backflow and check that the motor cooling fan has stopped. Start the pump again following the instructions of chapter 2.1.1 "Starting the pump".

## 2. OPERATION

---

### 2.2. Stopping the pump



It is advisable to close the discharge shut-off / regulation valve gradually and stop the motor immediately after. The reverse sequence is not recommended, especially with larger pumps or longer delivery piping. That is to avoid any problems due to water hammering. If a suction shutoff valve has been installed, it is advisable to close it completely.

### 2.3. Residual risks

Even with proper application and observance of all points listed in this operating manual, there is still an estimable and unexpected residual risk when using the pumps. It may leak, fail due to wear, application-related causes or system-related circumstances.

### 2.4. Disposal after expiration of the expected lifetime

The metallic components like aluminium, stainless steel and carbon steel can be recycled. Plastic parts are not recyclable and must be disposed of as residual waste. The pump must be disposed of properly, according to local regulations. It should be noted that potentially dangerous fluid residues may remain in the pump and can create a hazard to the operator or the environment, therefore the pump has to thoroughly cleaned before disposal.

### 2.5. Waste of electrical and electronic equipment (WEEE) directive

Users of electrical and electronic equipment (EEE) with the WEEE marking per Annex IV of the WEEE Directive must not dispose of end of life EEE as unsorted municipal waste, but use the collection framework available to them for the return, recycle, recovery of WEEE and minimize any potential effects of EEE on the environment and human health due to the presence of hazardous substances. The WEEE marking applies only to countries within the European Union (EU) and Norway. Appliances are labelled in accordance with European Directive 2002/96/EC. Contact your local waste recovery agency for a designated collection facility in your area.

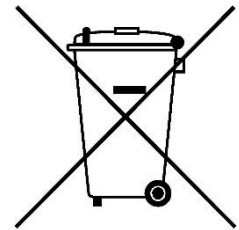

### 2.6. Actions in emergency

In case of a leakage of an unknown fluid, respiratory protection should be worn and contact with the fluid avoided. During firefighting, no special hazards are to be expected from the pump itself. In addition, the currently handled fluid and the corresponding safety data sheet must be taken into account.

In the event of personal injury, the appropriate emergency number or 112 must be chosen.

## 3. MAINTENANCE

---

### 3. MAINTENANCE



**Maintenance work on electrical installations must be performed by qualified personnel and only when the power supply has been shutoff. Follow the local and national safety regulations.**

**Wait five minutes for capacitor discharge before opening equipment.**

#### 3.1. Inspections

The CTM range pumps have been designed and tested to run for 5000 hours in ideal working conditions. Please note that it is a conservative figure since the actual duty point of your pump can substantially modify this value. Additional factors such as intermittent operation, type of pumped liquid and installation in the plant may affect the life of components that are subject to wear. In any case, Tapflo advises to service pumps every year, even when used in ideal operating conditions.

- Periodically check suction and discharge pressures.
- Inspect the motor according to the instructions from the motor manufacturer.



# 3. MAINTENANCE

## 3.2. Location of faults

Leakage from the pump	Insufficient flow rate or pressure in	No pressure on the discharge	Irregular discharge flow /	Noise and vibrations	The pump gets clogged	Overheating of the pump	Abnormal wear	Bushing life too short	Possible reason	Solution
X	X		X						Wrong direction of rotation	Invert the direction of rotation
	X	X	X	X					Insufficient suction head (NPSH)	Increase available NPSH: ➤ Raise the suction reservoir ➤ Lower the pump ➤ Reduce the vapour pressure ➤ Increase the diameter of the suction pipe ➤ Make suction pipe short and direct
		X							Pump is clogged	Clean the pump
X	X		X	X			X		Cavitation	Increase suction pressure
	X		X	X			X		The pump sucks air	Make sure all connections are tight
		X	X	X					Suction pipe is blocked	Check pipes / valves and filters on the suction line
	X			X					Discharge pressure too high	Reduce the head by increasing pipe diameter and/or reduce number of valves and bends
				X		X			Flow rate too high	Reduce the flow: ➤ Partially close the discharge valve ➤ Reduce the impeller diameter (contact us) ➤ Reduce the rotation speed
X	X			X	X	X	X		Liquid temperature too high	Cool the liquid
X								X	Pump runs dry	Always fill pump before start-up
								X	Wrong material of bushings for the liquid	Mount bushings in other material (contact us)
				X			X		Loads on the pipes	Connect the pipes independent of the pump
				X	X	X	X		Foreign objects in the liquid	Use a filter on the suction side
		X							Shut-off valve closed on suction side	Check and open the valve
	X								Discharge pressure too low	Increase the pressure – install an impeller with a bigger diameter (contact us)
					X	X			Pump is not filled with liquid	Fill pump with liquid
	X			X					Liquid parameters different than calculated	Check pumped liquid parameters
	X			X					Magnetic coupling damaged or insufficient	Check and replace magnet assemblies
				X					Rotating unit out of balance	Check and replace magnet assemblies
				X		X			Inner bushes worn or damaged	Check bushing and replace if necessary

## 3. MAINTENANCE

### 3.3. Disassembly of the pump



The disassembly should only be performed by qualified personnel.



Each operation carried out on the machine must always be carried out once all the electrical contacts have been disconnected. The pump-motor unit must be placed in a position where it cannot be started unintentionally.



Before servicing in any way the parts that come in contact with the pumped liquid, make sure that the pump has been fully emptied and washed. When draining the liquid, make sure that there is no danger for people or the environment.



The static and rotating bushings are usually made from very fragile sintered material and therefore have to be handled with extreme care.

The numbers put in brackets, refer to the part numbers in the spare part drawings and spare part lists in chapter 4 "Spare parts".

#### 3.3.1. Disassembly procedure



**Fig. 3.3.1**

Unscrew the casing mounting screws [141] and take off the pump casing [13].



**Fig. 3.3.2**

Pull out the front static bushing [1521] along with the O-ring [1821].

### 3. MAINTENANCE



**Fig 3.3.3**

Pull out the impeller / magnet assembly [90] from the isolation shell [12].



**NOTE!** Take extra care while proceeding with this point. The magnetic field generated by the magnets can cause finger seizure between the impeller and the impeller [90] and isolation shell [11].



**Fig 3.3.4**

Using a sharp tool take off the front rotating bushing [1511].

**NOTE!** Level the bushing equally on each side.



**Fig 3.3.5**

Using a sharp tool take off the rear rotating bushing [1512].

**NOTE!** Level the bushing equally on each side.



**Fig 3.3.6**

**CTM20** – Remove the O-ring [1812] from the impeller / magnet assembly.

**CTM25/32** – Remove the O-rings [1811, 1812] from the impeller / magnet assembly.



**Fig 3.3.7**

Remove the casing O-ring [18] form the isolation shell [12].

### 3. MAINTENANCE

---



**Fig 3.3.8**

Take out the isolation shell [12] form the lantern [11].



**Fig 3.3.9**

Pull out the rear static bushing [1522] along with the O-ring [1822].



**Fig 3.3.10**

Loosen the lock screws (2 x [161] on CTM20/25; 1 x [1611] and 2 x [1612] on CTM32).



**Fig 3.3.11**

Take out the external magnet assembly [16] form the lantern [11].



**Fig 3.3.12**

Unscrew the motor mounting screws [111] and remove the lantern [11] form the motor.

## 3. MAINTENANCE

---



The pump is now completely disassembled. Check all components, especially the O-rings and bushings, for wear or damage and replace if necessary.

The components that can affect the correct operation of the pump if not regularly replaced, are:

### CTM 20-7

- Casing O-ring (18)
- Rotating bushes (1511) + (1512)
- Static bushes (1521) + (1522)
- O-rings (1821) + (1812) + (1822)

### CTM 25-8, 25-10, 32-12,5, 40-12,5 and 50-12,5

- Casing O-ring (18)
- Rotating bushes (1511) + (1512)
- Static bushes (1521) + (1522)
- O-rings (1811) + (1821) + (1812) + (1822)

For spare part kits see chapter 4.3 Recommended spare parts.

## 3.4. Assembly of the pump

The assembly procedure is done in the reverse order to the disassembly.

Nevertheless there are a few things that you have to remember in order to assemble the pump correctly.



**Fig. 3.4.1**

Wet the O-rings with alcohol before assembly to make the procedure easier.

### 3.4.1. Test run



We recommend you to conduct a test run of the pump before installing it in the system, so no liquid gets wasted if the pump leaks or perhaps does not start accordingly to wrong assembly of the pump.

After a few weeks of operation retighten the screws with appropriate torque.

# 4. SPARE PARTS

## 4. SPARE PARTS

### 4.1. Spare parts drawing

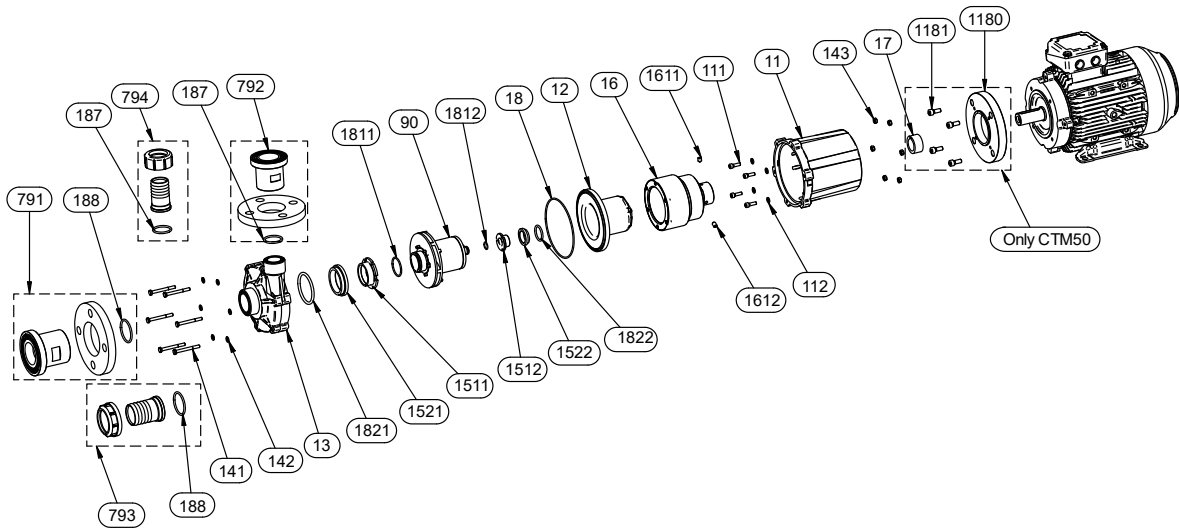

### 4.2. Spare parts list

Pos.	Description	Pump model						Material
		20-7	25-8	25-10	32-12,5	40-12,5	50-12,5	
11	Lantern	1	1	1	1	1	1	PP-GF (30%)
111	Motor mounting screw	4	4	4	4	4	4	A4-70
112	Motor mounting washer	-	-	-	4	4	4	A4-70
1180	Motor adaptive flange	-	-	-	-	-	1	Aluminium
1181	Flange mounting screw	-	-	-	-	-	4	A4-70
12	Isolation shell (rear casing)	1	1	1	1	1	1	PP-GF (30%), PVDF
13	Pump casing	1	1	1	1	1	1	PP-GF (30%), PVDF
141	Casing mounting screw	6	6	6	6	6	6	A4-70
142	Casing mounting washer	6	6	6	6	6	6	A4-70
143	Casing mounting nut	6	6	6	6	6	6	A4-70
1511	Front rotating bushing	1	1	1	1	1	1	PTFE – graphite, SiC
1512	Rear rotating bushing	1	1	1	1	1	1	PTFE – graphite, SiC
1521	Front static bushing	1	1	1	1	1	1	Al <sub>2</sub> O <sub>3</sub> (ceramic), SiC
1522	Rear static bushing	1	1	1	1	1	1	Al <sub>2</sub> O <sub>3</sub> (ceramic), SiC
16	External magnet assembly	1	1	1	1	1	1	Cast iron / NdFeB
161	Lock screw	2	2	2	-	-	-	St 45H
1611	Lock screw	-	-	-	1	1	1	St 45H
1612	Lock screw	-	-	-	2	2	2	St 45H
17	Spacer sleeve	-	-	-	-	-	1	Aluminium
18	Casing O-ring	1	1	1	1	1	1	EPDM, FKM
1811	O-ring	-	1	1	1	1	1	EPDM, FKM
1812	O-ring	1	1	1	1	1	1	EPDM, FKM
1821	O-ring	1	1	1	1	1	1	EPDM, FKM
1822	O-ring	1	1	1	1	1	1	EPDM, FKM
90	Impeller	1	1	1	1	1	1	PP / NdFeB, PVDF / NdFeB
		<b>OPTIONS</b>						
187	O-ring	2*	2*	2*	1	1	1	EPDM, FKM
188	O-ring	-	-	-	1	1	1	EPDM, FKM
791	Flange connection on inlet	2*	2*	2*	1	1	1	PP, PVDF
792	Flange connection on outlet	-	-	-	1	1	1	PP, PVDF
793	Hose connection on inlet	2*	2*	2*	1	1	1	PP, PVDF
794	Hose connection on outlet	-	-	-	1	1	1	PP, PVDF

\* CTM20/25 has the same size of inlet/outlet

## 4. SPARE PARTS

### 4.3. Recommended spare parts

Depending on the nature of the liquid and temperature etc., some parts of the pump are subject to wear and have to be replaced. We recommend having the following parts in stock:

- O-ring KIT (xx-y – pump size, e.g. 25-10; z – material, E for EPDM, V for FKM):

CTMxx-y zOR KIT		
Pos.	Description	Q-ty
18	Casing O-ring	1
1811	O-ring	1
1812	O-ring	1
1821	O-ring	1
1822	O-ring	1

- WETEND (xx-y – pump size, e.g. 25-10; z – material, P for PP, K for PVDF):

WETEND-CTMxx-yz		
Pos.	Description	Q-ty
12	Isolation shell (rear casing)	1
13	Pump casing	1
141	Casing mounting screw	6
142	Casing mounting washer	6
143	Casing mounting nut	6
1511	Front rotating bushing	1
1512	Rear rotating bushing	1
1521	Front static bushing	1
1522	Rear static bushing	1
18	Casing O-ring	1
1811	O-ring	1
1812	O-ring	1
1821	O-ring	1
1822	O-ring	1
90	Impeller	1

### 4.4. How to order parts

When ordering spare parts for Tapflo pumps, please let us know what is the **model number** and **serial number** from the pump's name plate. Then just indicate the part numbers from the spare parts list and quantity of each item.

# 5. DATA

## 5. DATA

### 5.1. Pump code

The model number on the pump and on the front page of this instruction manual tells the pump size and materials of the pump.

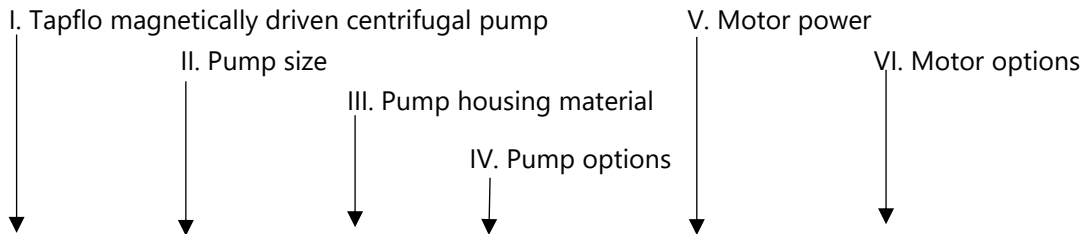

<b>CTM</b>	<b>25-10</b>	<b>P</b>	<b>-1V</b>	<b>-05</b>	<b>P</b>
------------	--------------	----------	------------	------------	----------

**I. CTM = Tapflo magnetically driven centrifugal pump**

**II. Pump size:**

20-7  
25-8  
25-10  
32-12.5  
40-12.5  
50-12.5

**III. Pump housing material:**

P = PP (Polypropylene)  
K = PVDF (Polyvinylidene fluoride)

**IV. Pump options:**

**1. All O-rings:**

blank\* = same material as in mechanical seal  
F = FEP / FKM  
V = FKM  
E = EPDM  
K = FFKM

**2. Static bushing:**

blank\* = Al<sub>2</sub>O<sub>3</sub> (ceramic)  
S = SiC (silicone carbide)

**3. Rotating bushing:**

blank\* = PTFE-graphite  
S = SiC (silicone carbide)

**4. Connection options:**

blank\* = BSP external thread  
F = Flange DIN PN10 (CTM20, CTM25);  
PN16 (CTM32, CTM40, CTM50)  
H = Hose connection  
A = ANSI flange

**5. Other options:**

I = Optional impeller diameter [mm]  
M = Motor cover- industrial version  
HL = Horizontal pump outlet

**V. Motor power / IEC mechanical size:**

01 = 0.12 kW / 56  
02 = 0.25 kW / 63  
05 = 0.55 kW / 71  
07 = 0.75 kW / 80  
11 = 1.1 kW / 80  
15 = 1.5 kW / 90  
22 = 2.2 kW / 90  
30 = 3.0 kW / 100  
40 = 4.0 kW / 112

**VI. Motor options**

P = 1-phase motor (220/230 VAC)  
V = 500 V motor  
T = PTC motor protection  
F60 = 60 Hz motor

\* = standard execution



# 5. DATA

## 5.2. Dimensions

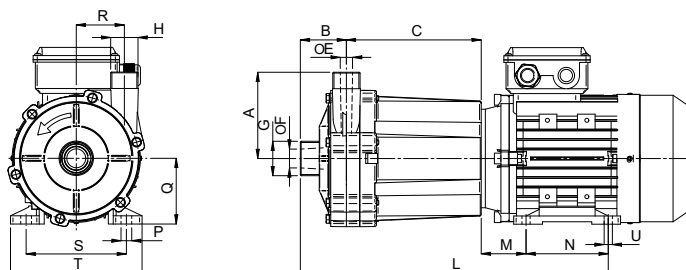

Dimensions in mm (where other is not indicated)

Dimensions in inch (where other is not indicated)

General dimensions only, ask us for detailed drawings. Changes reserved without notice.

MODEL	CTM20-7	CTM25-8	CTM25-10	CTM32-12.5	CTM40-12.5	CTM50-12.5			
A	70	90	100	105	105	110			
	2.76	3.54	3.94	4.13	4.13	4.33			
B	48	58.50	63	56	56.5	54			
	1.89	2.30	2.48	2.20	2.22	2.13			
C	93.5	100.5	136.5	164	165	189			
	3.68	3.96	5.37	6.46	6.50	7.44			
ØE	15	18	18	15	23	30.8			
	0.59	0.71	0.71	0.59	0.91	1.21			
ØF	15	18	18	23	30.5	42			
	0.59	0.71	0.71	0.91	1.20	1.65			
G	¾"	1"	1"	1 ¼"	1 ½"	2"			
	¾	1	1	1 ¼	1 ½	2			
H	¾"	1"	1"	1"	1 ¼"	1 ½"			
	¾	1	1	1	1 ¼	1 ½			
L	248.5	279	334.5	374.5	402.5	446	453		
	9.78	10.98	13.17	14.74	15.85	17.56	17.83		
M	36	40	45	54.5	56	63	70		
	1.42	1.57	1.77	2.15	2.20	2.48	2.76		
N*	71	80	80	100	125	140			
	2.80	3.15	3.15	3.94	4.92	5.51			
P*	9	10	10	13	14	15			
	0.22	0.28	0.28	0.51	0.55	0.59			
Q	56	63	71	80	90	100	112		
	2.20	2.48	2.80	3.15	3.54	3.94	4.41		
R	35	39.5	43.5	58.5	58.5	52			
	1.38	1.56	1.71	2.30	2.30	2.05			
S*	90	100	112	125	140	160	190		
	3.54	3.94	4.41	4.92	5.51	6.30	7.48		
T	112	126	141	160	170	200	230		
	4.41	4.96	5.55	6.30	6.69	7.87	9.06		
U*	5,5	7	7	10	10	12			
	0.22	0.28	0.28	0.39	0.39	0.47			
<b>MOTOR</b>									
POWER	0.12 kW	0.25 kW	0.55 kW	0.75 kW	1.1 kW	1.5 kW	2.2 kW	3.0 kW	4.0 kW
SIZE	56	63	71	80	80	90	90	100	112
WEIGHT* PP [kg]	4.3	5.7	8.75	14	15.7	24	25.5	31.55	32.55
WEIGHT* PVDF	4.45	5.9	9.2	14.5	16.2	24.65	26.2	32.15	33.15
Max. S.G.**	1.2	1.2	1.3	1	1.6	1.2	1.7	1.5	2.0
<b>OPTIONAL CONNECTIONS</b>									
FLANGE	-	DN25	DN25	DN32 / DN25	DN40 / DN32	DN50 / DN40			
HOSE	-	Ø25	Ø25	Ø32 / Ø25	Ø40 / Ø32	Ø50 / Ø40			

\*The dimensions and weights may vary depending on motor brand

\*\* If you need to pump more dense liquids, please contact Tapflo for advice





## 5. DATA

### 5.3. Materials, data and limits

<b>Casing and isolation shell</b>	PP-GF (30%) or PVDF
<b>Impeller</b>	PP or PVDF
<b>Lantern (not wetted)</b>	PP-GF (30%)
<b>Static bushings</b>	Ceramic (standard) or SiC
<b>Rotating bushings</b>	PTFE-graphite (standard) or SiC
<b>O-rings</b>	FKM, EPDM, FFKM, FEP/FKM
<b>Magnets</b>	NdFeB
<b>Motor</b>	IEC standard, 3x400 VAC (other on request), 2900 rpm, IP55, B34 frame
<b>Pressure rating</b>	<b>CTM20:</b> PP pumps: PN4 at 20°C, PN2 at 70°C PVDF pumps: PN4 at 20°C, PN2 at 80°C <b>CTM25, CTM32, CTM40 and CTM50:</b> PP pumps: PN6 at 20°C; PN2 at 70°C PVDF pumps: PN6 at 20°C; PN2 at 90°C
<b>Temperature</b>	PP pumps: 0°C - 70°C PVDF pumps: -20°C - 80°C (CTM20); -20°C - 90°C (CTM25, 32, 40, 50)
<b>Kinematic viscosity</b>	100 cSt (max)
<b>Dynamic viscosity</b>	10 cP (max)
<b>Solids</b>	Max solids size – 100 µm Max solids concentration by weight – 2%
<b>Max specific gravity</b>	

### 5.4. Mounting torques and dimensions of screws/nuts

The following tightening torques are recommended :

Screw / nut type	Description	Pump model					
		CTM 20-7	CTM 25-8	CTM 25-10	CTM 32-12,5	CTM 40-12,5	CTM 50-12,5
	<b>Pos. 141 hexagonal screw</b> Mounting torque [Nm] Thread	6 M5	9 M6	9 M6	9 M6	9 M6	9 M6
	<b>Pos. 143 hexagonal nut</b> Mounting torque [Nm] Thread	6 M5	9 M6	9 M6	9 M6	9 M6	9 M6
	<b>Pos. 111 allen screw</b> Mounting torque [Nm] Thread	6 M5	6 M5	9 M6	9 M6	14 M8	9 M6
	<b>Pos. 1181 allen screw</b> Mounting torque [Nm] Thread	- -	- -	- -	- -	- -	14 M8

# 5. DATA

## 5.5. Tightening torques

Checking of the tightening torques is necessary after periods of stoppage, when temperature variations are a factor or after transport and maintenance of the pump.

What is more for proper operation and safety the torque values should be checked frequently as part of preventive maintenance (please contact Tapflo for interval proposals). Although pump applications vary, a general guideline is to re-torque the pump every two weeks.

## 5.6. Performance curves

The performance curves are based on water at 20°C. Speed 2900 rpm.

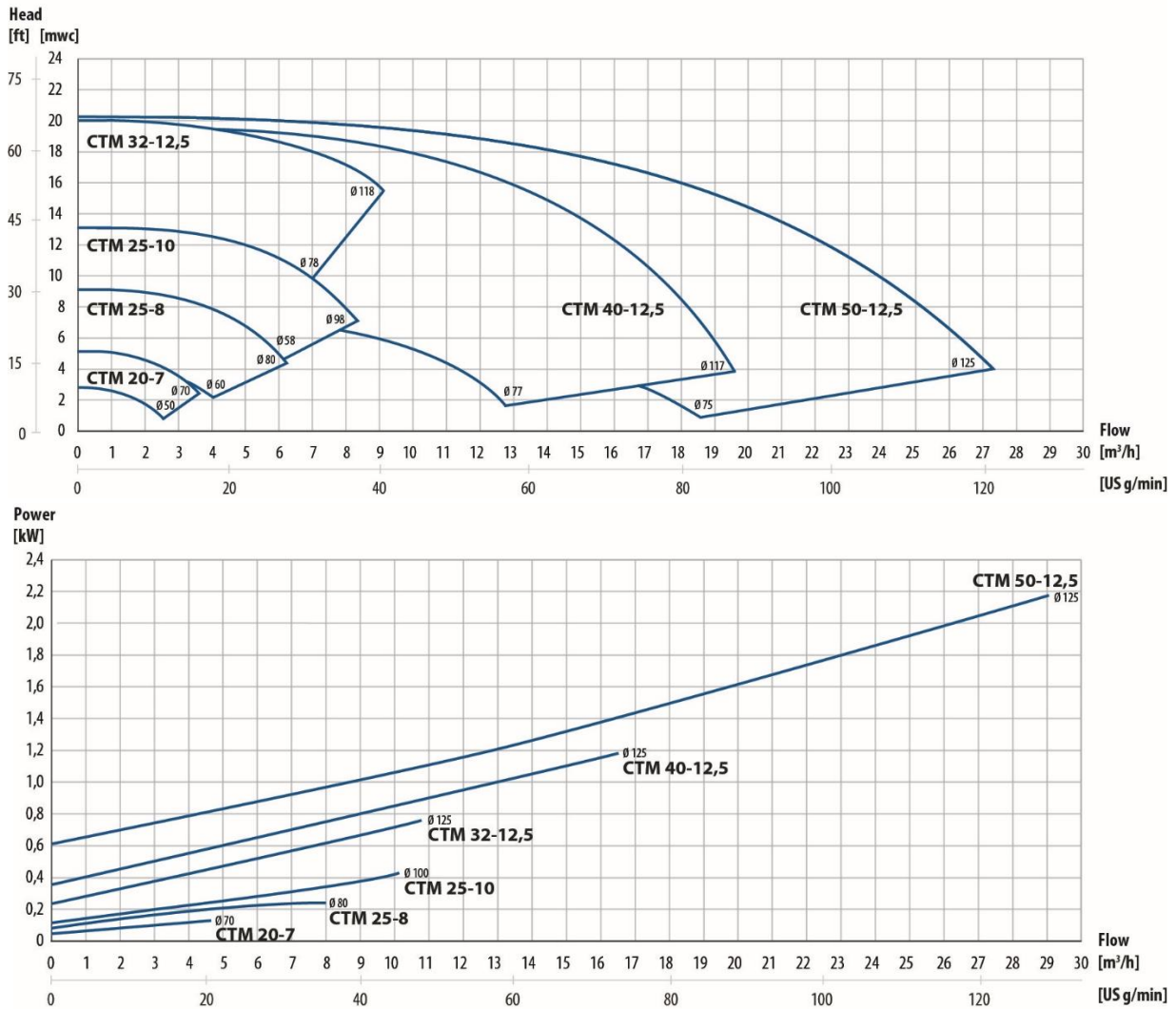

See Tapflo Infopack for detailed curves.

# 5. DATA

## 5.7. Permitted loads on inlet and outlet

We recommend not to exceed the following loads and forces reacting on the inlet and outlet.

CTM 20		
Direction	Load [N] (inlet/outlet)	Moment of force (inlet/outlet) [Nm]
X	15	3
Y	20	4
Z	15	3

CTM 25		
Direction	Load [N] (inlet/outlet)	Moment of force (inlet/outlet) [Nm]
X	15	3
Y	20	4
Z	15	3

CTM 32		
Direction	Load [N] (inlet/outlet)	Moment of force (inlet/outlet) [Nm]
X	15	3
Y	20	4
Z	15	3

CTM 40		
Direction	Load [N] (inlet/outlet)	Moment of force (inlet/outlet) [Nm]
X	15	3
Y	20	4
Z	15	3

CTM 50		
Direction	Load [N] (inlet/outlet)	Moment of force (inlet/outlet) [Nm]
X	15	3
Y	20	4
Z	15	3

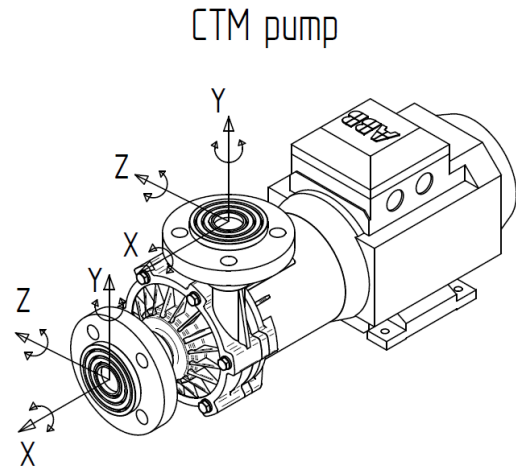

# 6. WARRANTY

---

## 6. WARRANTY

### 6.1. Returning parts

When returning parts to Tapflo please follow this procedure:

- Consult Tapflo for shipping instructions.
- Cleanse or neutralize and rinse the part/pump. Make sure the part/pump is completely empty from liquid.
- Pack the return articles carefully to prevent any damage during transportation.

***Goods will not be accepted unless the above procedure has been complied with.***

### 6.2. Warranty

Tapflo warrants products under conditions as stated below for a period of not more than 12 months from installation and not more than 24 months from date of manufacturing.

1. The following terms and conditions apply to the sale of machinery, components and related services and products, of Tapflo (hereinafter "the products").
2. Tapflo (the manufacturer) warrants that:
  - a. its products are free of defects in material, design and workmanship at the time of original purchase;
  - b. its products will function in accordance with Tapflo operative manuals; Tapflo does not guarantee that the product will meet the precise needs of the Customer, except for those purposes set out in any invitation to render documents or other documents specifically made available to Tapflo before entering into this agreement;
  - c. high quality materials are used in the construction of the pumps and that machining and assembly are carried out to the highest standards.

Except as expressly stated above, Tapflo makes no warranties, express or implied, concerning the products, including all warranties of fitness for a particular purpose.

3. This warranty shall not be applicable in circumstances other than defects in material, design, and workmanship. In particular warranty shall not cover the following:
  - a. Periodic checks, maintenance, repair and replacement of parts due to normal wear and tear (seals, O-rings, rubber items, bushings, etc.);
  - b. Damage to the product resulting from:
    - b.1. Tampering with, abuse or misuse, including but not limited to failure to use the product for its normal purposes as stated at the time of purchase or in accordance with Tapflo instructions for use and maintenance of the product, or the installation or improper ventilation or use of the product in a manner inconsistent with the technical or safety standard in force;

## 6. WARRANTY

---

- b.2. Repairs performed by non-skilled personnel or use of non-original Tapflo parts;
  - b.3. Accidents or any cause beyond the control of Tapflo. including but not limited to lightning. water. fire. earthquake. and public disturbances. etc.;
4. The warrantee shall cover the replacement or repairing of any parts. which is documented faulty due to construction or assembling. with new or repaired parts free of charges delivered by Tapflo. Parts subjected to normal tear and wear shall not be covered by the warranty. Tapflo shall decide as to whether the defective or faulty part shall be replaced or repaired.
  5. The warrantee of the products shall be valid for a period in accordance to the current law from the date of delivery. under the condition that notice of the alleged defect to the products or parts thereof be given to Tapflo in written within the mandatory term of 8 days from the discovery. Repair or replacement under the terms of this warranty shall not give a right to an extension to. or a new commencement of. the period of warranty.
  6. Repair or replacement under the terms of this warranty shall not give a right to an extension to, or a new commencement of, the period of warranty. Repair or replacement under the terms of this warranty may be fulfilled with functionally equivalent reconditioned units. Tapflo qualified personnel shall be solely entitled to carry out repair or replacement of faulty parts after careful examination of the pump. Replaced faulty parts or components will become the property of Tapflo.
  7. The products are built in accordance with standard CE normative and are tested (where applicable) by Tapflo. Approval and tests by other control authority are for the customer's account. The products shall not be considered defective in materials. design or workmanship if they need to be adapted. changed or adjusted to conform to national or local technical or safety standards in force in any country other than that for which the unit was originally designed and manufactured. This warranty shall not reimburse such adaptations. changes or adjustments. or attempt to do so. whether properly performed or not. nor any damage resulting from them. nor any adaptation. change or adjustments to upgrade the products from their normal purpose as described in the products operative manual without the prior written consent of Tapflo.
  8. Installation. including electric and other connections to utility mains according to Tapflo drawings. is for the cost and responsibility of the customer. unless otherwise agreed in writing.
  9. Tapflo will not be liable on any claim. whether in contract. tort. or otherwise. for any indirect. special. incidental. or consequential damages. caused to the customer or to third parties. including loss of profits. arising by any possible infringement of par. 3 above or by the customer or third parties being in the impossibility of using the products.

Steady the above. Tapflo liability to the customer or third parties from any claim. whether in contract. tort. or otherwise. shall be limited to the total amount paid by the customer for the product that caused the damages

# 6. WARRANTY

## 6.3. Warranty form

Company: _____			
Telephone: _____		Fax: _____	
Address: _____			
Country: _____		Contact Name: _____	
E-mail: _____			
Delivery Date: _____		Date of pump installation: _____	
Pump type: _____			
Serial No (see name plate): _____			
Description of the fault: _____			
_____			
_____			
<b>The installation:</b>			
Liquid: _____			
Temperature [°C]: _____	Viscosity [cPs]: _____	Spec grav. [kg/m <sup>3</sup> ]: _____	pH-value: _____
Content of particles: _____		% of max size [mm]: _____	
Flow [l/min]: _____	Duty [h/day]: _____	No of starts per day: _____	
Discharge head [mWC]: _____		Suction head / lift [m]: _____	
Other: _____			
_____			
<b>Place for sketch of installation:</b>			

## Sweden

Filaregatan 4 | S-442 34 Kungälv

Tel: +46 303 63390

Fax: +46 303 19916

E-mail addresses:

Commercial questions: [sales@tapflo.com](mailto:sales@tapflo.com)

Orders: [order@tapflo.com](mailto:order@tapflo.com)

Tech support: [support@tapflo.com](mailto:support@tapflo.com)

## Tapflo products and services are available worldwide.

Tapflo is represented by own Tapflo Group Companies and carefully selected distributors assuring highest Tapflo service quality for our customers' convenience.

AUSTRALIA | AUSTRIA | AZERBAIJAN | BAHRAIN | BELGIUM | BOSNIA | BRAZIL | BULGARIA | CANADA | CHILE | CHINA | COLOMBIA | CROATIA | CZECH REPUBLIC | DENMARK | ECUADOR | EGYPT | ESTONIA | FINLAND | FRANCE | GEORGIA | GERMANY | GREECE | HONG-KONG | HUNGARY | ICELAND | INDIA | INDONESIA | IRELAND | ISRAEL | ITALY | JAPAN | JORDAN | KAZAKHSTAN | KUWAIT | LATVIA | LIBYA | LITHUANIA | MACEDONIA | MALAYSIA | MEXICO | MONTENEGRO | MOROCCO | NETHERLANDS | NEW ZEALAND | NORWAY | OMAN | PHILIPPINES | POLAND | PORTUGAL | QATAR | ROMANIA | SAUDI ARABIA | SERBIA | SINGAPORE | SLOVAKIA | SLOVENIA | SOUTH AFRICA | SOUTH KOREA | SPAIN | SWEDEN | SWITZERLAND | TAIWAN | THAILAND | TURKEY | UKRAINE | UNITED ARAB EMIRATES | UNITED KINGDOM | USA | UZBEKISTAN | VIETNAM

## Tapflo Group Companies

### Australia

Tapflo Oceania (Pty) Ltd.  
Tel: +61 1800303633  
[sales@tapflo.com.au](mailto:sales@tapflo.com.au)

### China

Tapflo (Wuxi) Pumps Co. Ltd.  
Tel: +86 51082417072  
[sales@tapflo.cn](mailto:sales@tapflo.cn)

### Ireland

Tapflo Ireland Ltd.  
Tel: +353 12011911  
[info@tapflo.ie](mailto:info@tapflo.ie)

### Poland

Tapflo Sp. z o.o.  
Tel: +48 585304212  
[info@tapflo.pl](mailto:info@tapflo.pl)

### Spain

Tapflo Ibérica S.L.  
Tel: +34 918093182  
[avives@tapfloiberica.es](mailto:avives@tapfloiberica.es)

### Uzbekistan

Tapflo Uzbekistan  
Tel: +998 712370940  
[sales@tapflo.uz](mailto:sales@tapflo.uz)

### Austria

Tapflo GmbH  
Tel: +43 73227292910  
[sales@tapflo.at](mailto:sales@tapflo.at)

### Croatia

Tapflo d.o.o.  
Tel: +385 914884666  
[sales@tapflo.hr](mailto:sales@tapflo.hr)

### Italy

Tapflo Italia S.r.l.  
Tel: +39 0362306528  
[info@tapfloitalia.com](mailto:info@tapfloitalia.com)

### Qatar

Tapflo Gulf General Trading Co. L.L.C  
Tel: +971 58 582 3630  
[sales@tapflogulf.com](mailto:sales@tapflogulf.com)

### South Africa

Tapflo (Pty) Ltd.  
Tel: +27 317015255  
[sales@tapflo.co.za](mailto:sales@tapflo.co.za)

### Bahrain

Tapflo Gulf General Trading Co. L.L.C  
Tel: +971 58 582 3630  
[sales@tapflogulf.com](mailto:sales@tapflogulf.com)

### Czech Republic

Tapflo s.r.o.  
Tel: +420 513033924  
[tapflo@tapflo.cz](mailto:tapflo@tapflo.cz)

### Japan

Tapflo Japan K.K.  
Tel: +81 362403510  
[tapflojp@tapflo.co.jp](mailto:tapflojp@tapflo.co.jp)

### Romania

S.C. Tapflo Rom. S.r.l.  
Tel: +40 213451255  
[sales@tapflo.ro](mailto:sales@tapflo.ro)

### Sweden

Tapflo AB  
Tel: +46 (0)30314050  
[info@tapflo.com](mailto:info@tapflo.com)

### Baltic States

Tapflo SIA  
Tel: +371 67472205  
[sales@tapflo.lv](mailto:sales@tapflo.lv)

### Denmark

Tapflo Danmark ApS  
Tel: +45 36454600  
[info@tapflo.dk](mailto:info@tapflo.dk)

### Kazakhstan

Tapflo LLP  
Tel: +7 7273278347  
[sales@tapflo.kz](mailto:sales@tapflo.kz)

### Saudi Arabia

Tapflo Gulf General Trading Co. L.L.C  
Tel: +971 58 582 3630  
[sales@tapflogulf.com](mailto:sales@tapflogulf.com)

### Turkey

Tapflo Makina Ltd.  
Tel: +90 2164673311  
[sales@tapflo.com.tr](mailto:sales@tapflo.com.tr)

### Belgium

Tapflo Benelux B.V.  
Tel: +31 (0)850074300  
[info@tapflo.nl](mailto:info@tapflo.nl)

### France

Sarl Tapflo France  
Tel: +33188788240  
[info@tapflo.fr](mailto:info@tapflo.fr)

### Kuwait

Tapflo Gulf General Trading Co. L.L.C  
Tel: +971 58 582 3630  
[sales@tapflogulf.com](mailto:sales@tapflogulf.com)

### Serbia

Tapflo d.o.o.  
Tel: +381 21445808  
[sales@tapflo.rs](mailto:sales@tapflo.rs)

### Ukraine

Tapflo LLC  
Tel: +380 442226844  
[sales@tapflo.ua](mailto:sales@tapflo.ua)

### Bulgaria

Tapflo EOOD  
Tel: +359 (0)29741854  
[office@tapflo.bg](mailto:office@tapflo.bg)

### Hungary

Tapflo Kft.  
Tel: +36 30148 8551  
[office@tapflo.hu](mailto:office@tapflo.hu)

### Netherlands

Tapflo Benelux B.V.  
Tel: +31 (0)850074300  
[info@tapflo.nl](mailto:info@tapflo.nl)

### Slovakia

Tapflo s.r.o.  
Tel: +421 911137883  
[tapflo@tapflo.sk](mailto:tapflo@tapflo.sk)

### United Arab Emirates

Tapflo Gulf General Trading Co. L.L.C  
Tel: +971 58 582 3630  
[sales@tapflogulf.com](mailto:sales@tapflogulf.com)

### Canada

Tapflo Canada  
Tel: +1 5148135754  
[canada@tapflo.com](mailto:canada@tapflo.com)

### India

Tapflo Fluid Handling India Pvt Ltd.  
Tel: +91 2065000215  
[ac@tapflo.in](mailto:ac@tapflo.in)

### Oman

Tapflo Gulf General Trading Co. L.L.C  
Tel: +971 58 582 3630  
[sales@tapflogulf.com](mailto:sales@tapflogulf.com)

### Slovenia

Tapflo d.o.o.  
Tel: +386 68613474  
[sales@tapflo.hr](mailto:sales@tapflo.hr)

### United Kingdom

Tapflo (UK) Ltd.  
Tel: +44 2380252325  
[sales@tapflo pumps.co.uk](mailto:sales@tapflo pumps.co.uk)



If your country is not listed please visit [www.tapflo.com/en/contact](http://www.tapflo.com/en/contact)